

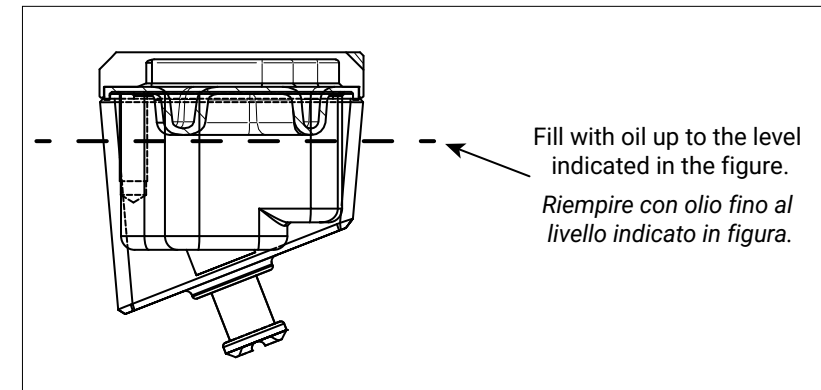

Installation video

<https://youtu.be/rfjABOhPQMq>

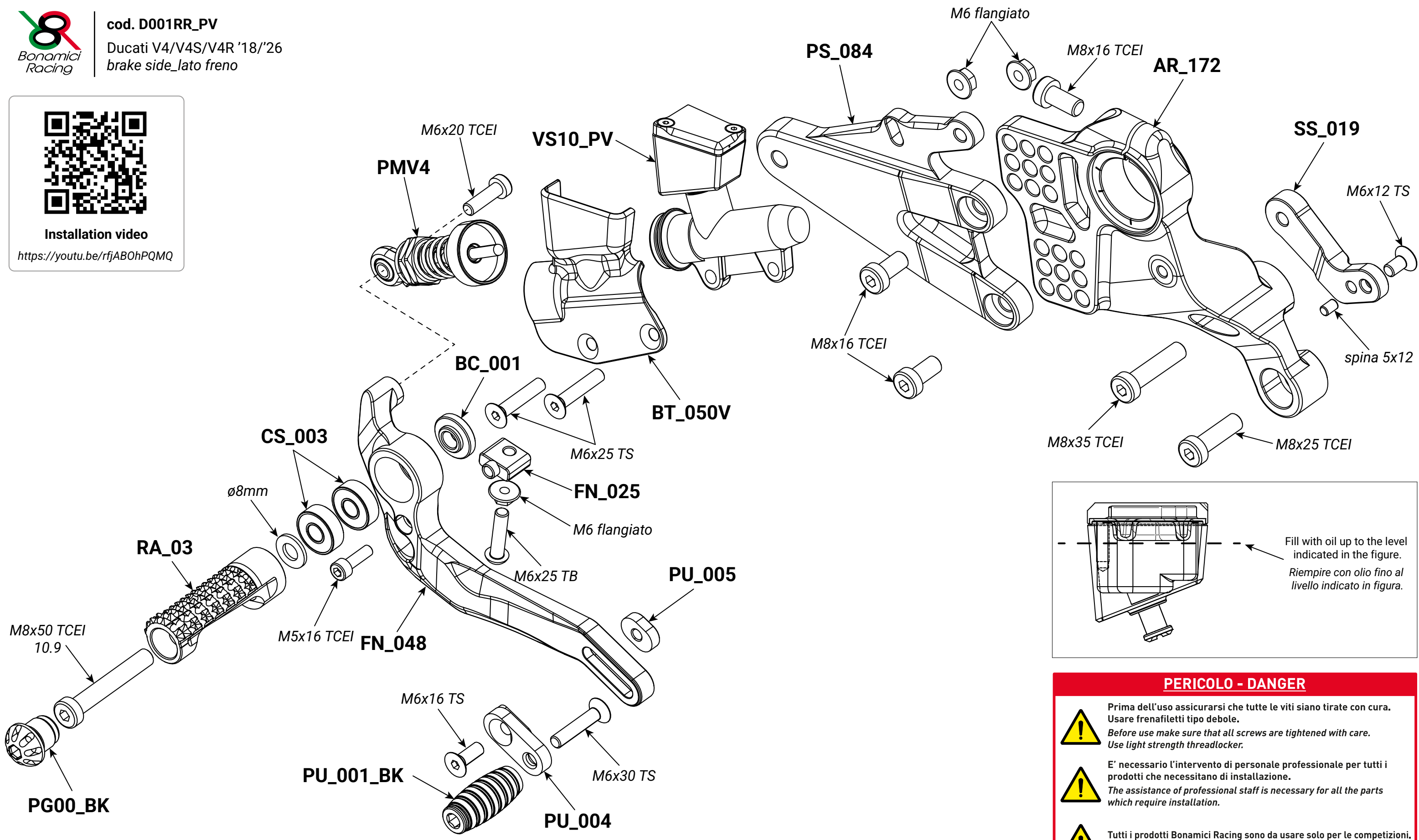

Fill with oil up to the level indicated in the figure.
Riempire con olio fino al livello indicato in figura.

PERICOLO - DANGER



Prima dell'uso assicurarsi che tutte le viti siano tirate con cura. Usare frenafilletti tipo debole.
Before use make sure that all screws are tightened with care. Use light strength threadlocker.



E' necessario l'intervento di personale professionale per tutti i prodotti che necessitano di installazione.
The assistance of professional staff is necessary for all the parts which require installation.



Tutti i prodotti Bonamici Racing sono da usare solo per le competizioni.
All Bonamici Racing products are made for agonistic use only.



A seguito di qualsiasi urto è obbligatorio sostituire le parti interessate.
After any kind of impact, it's obligatory to replace the affected parts.



E' obbligatorio controllare il serraggio delle viti dopo ogni sessione di guida.
It's obligatory to check the tightened of the screws after ever ride session.

*tightening torque - *coppia di serraggio

M5 TS	8,48 Nm*
M6 TS	14,71 Nm*
M8 TS	35,30 Nm*
M6 TCEI - TB	10,30 Nm*
M8 TCEI - TB	25,50 Nm*



Installation video

<https://youtu.be/rfjABOhPQMq>

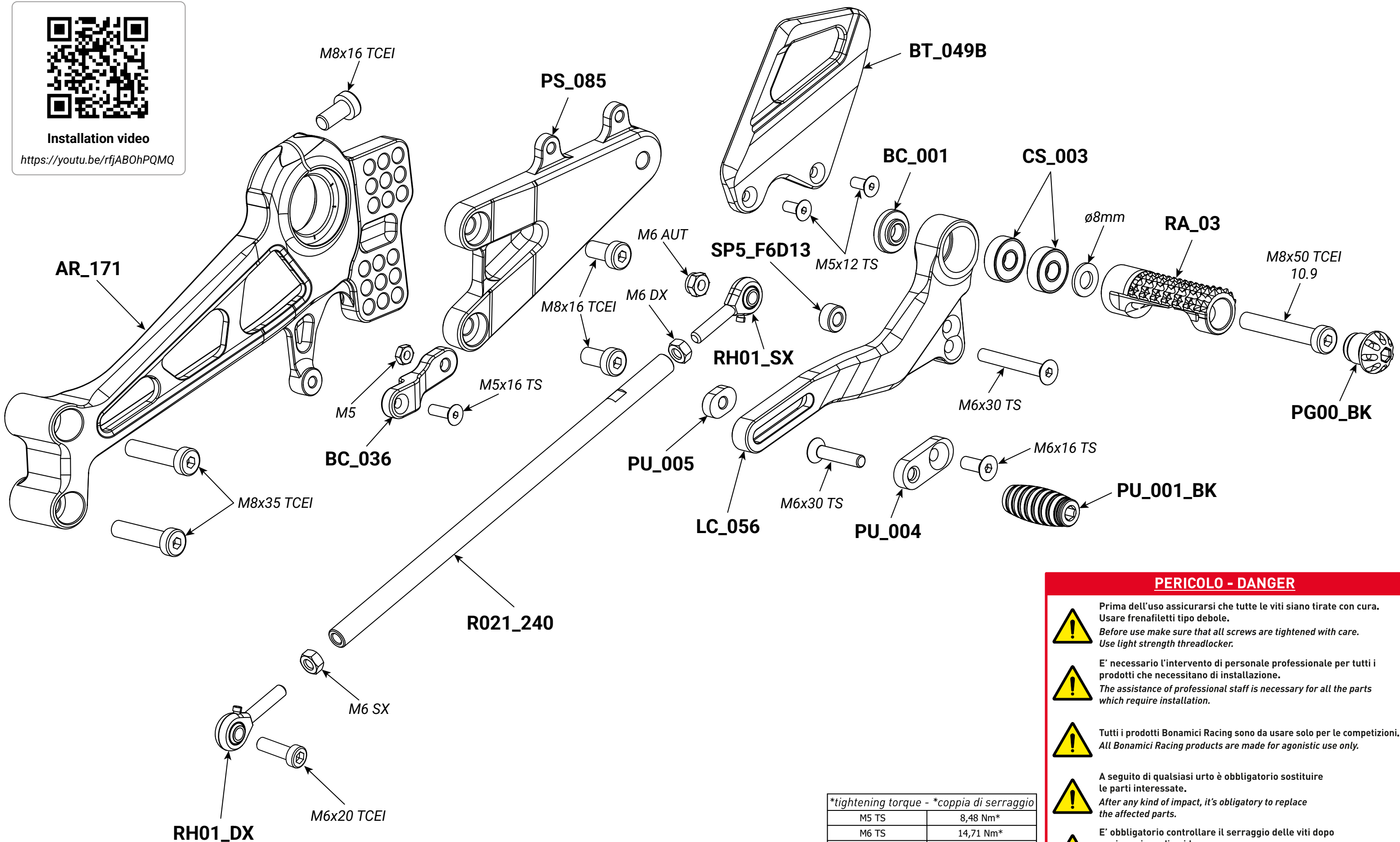

PERICOLO - DANGER



Prima dell'uso assicurarsi che tutte le viti siano tirate con cura. Usare frenafili tipo debole.
Before use make sure that all screws are tightened with care. Use light strength threadlocker.



E' necessario l'intervento di personale professionale per tutti i prodotti che necessitano di installazione.
The assistance of professional staff is necessary for all the parts which require installation.



Tutti i prodotti Bonamici Racing sono da usare solo per le competizioni. All Bonamici Racing products are made for agonistic use only.



A seguito di qualsiasi urto è obbligatorio sostituire le parti interessate.
After any kind of impact, it's obligatory to replace the affected parts.



E' obbligatorio controllare il serraggio delle viti dopo ogni sessione di guida.
It's obligatory to check the tightened of the screws after ever ride session.

*tightening torque - *coppia di serraggio

M5 TS	8,48 Nm*
M6 TS	14,71 Nm*
M8 TS	35,30 Nm*
M6 TCEI - TB	10,30 Nm*
M8 TCEI - TB	25,50 Nm*